

PLANT ROOM VALVES

Automatic Air Eliminators and Boiler Vent Valves



- ▶ Proven reliability extending over long service life
- ▶ Robust construction and reliable operation for industrial environments
- ▶ AAEs suitable for use with fresh water, aviation fuels, diesel, light oils and glycol
- ▶ Manufactured from body materials resistant to stress corrosion cracking
- ▶ AAE units available to suit different pressures and temperatures

OUR GENIUS IS VALVES

PLANT ROOM VALVES



Automatic Air Eliminators and Boiler Vent Valves

With a proven track record for high quality, Brownall offers an exclusive range of Automatic Air Eliminators (AAE) covering low, medium and high pressure applications, complemented by the Three-way Vent Valves and Vent Cocks for boilers.

Offering efficient performance, the Brownall range removes inevitable and potentially dangerous air trapped in the system. Air Eliminators are suitable for use with water, glycol, aviation fuel, diesel and light oils.

Installed at the highest point of the fluid carrying system, the trapped air will enter the float chamber of the air eliminator. This reduces the float buoyancy and allows air to escape through the outlet orifice.

To compliment the AAE, the Univent and Vent Cocks are installed to provide a direct connection from the boiler to the atmosphere. Designed to simplify the venting process, for single or multi point boiler and calorifier installations, the range offers savings in time and costs. Bronze body parts enable the range to operate in high turbulence, aerated hot water, which can be a very corrosive environment.

All the above make Brownall the number one choice with professional building services, consulting engineers and specifying authorities.

Air separation saves the system!

Air in a central heating system can lead to a reduced heat emission and has harmful consequences for the whole installation- particularly the pump, which is often the first component to suffer damage. Air leads to noisy installation, loss of performance, corrosion and premature failure. Installing good venting equipment can help alleviate these problems.

The importance of a clean system

Dirt or other foreign matter can cause problems which reduces the efficiency of the system, particularly in the case of air elimination. It is therefore recommended that the system is flushed prior to installing the Automatic Air Eliminator. In addition, a pipeline strainer should be installed immediately before the inlet to the AAE.

Brownall recommends that discharge pipework should be fitted to the outlet of the valves to allow for venting and water carry-over.

Selection of the most suitable Automatic Air Eliminator

There are several types of air eliminator available so evaluating system requirements is essential. The following factors must be taken into consideration:

- **System Parameters**
For systems operating at 10 bar and 93°C, use Type A, B and D AAEs on the pump outlet where there is positive pressure. The Type C is fitted with a non return valve that allows air to be removed from the system, but stops air being drawn in where there is negative pressure on a pump inlet. Use MPHW and HPHW air eliminators on the pump outlet where there is a positive pressure. Ensure that the pressure and temperature rating meet the requirements of the system.
- **Materials of Construction**
Quality of manufacture and materials used in construction are critical. All pressure containing parts are bronze. Corrosion and clogging of valve mechanisms are potential problems if incorrect materials are used.
- **Reliability**
An automatic valve, usually operating in an inaccessible roof space or system header, must be capable of long term, trouble free operation.

Features & Benefits

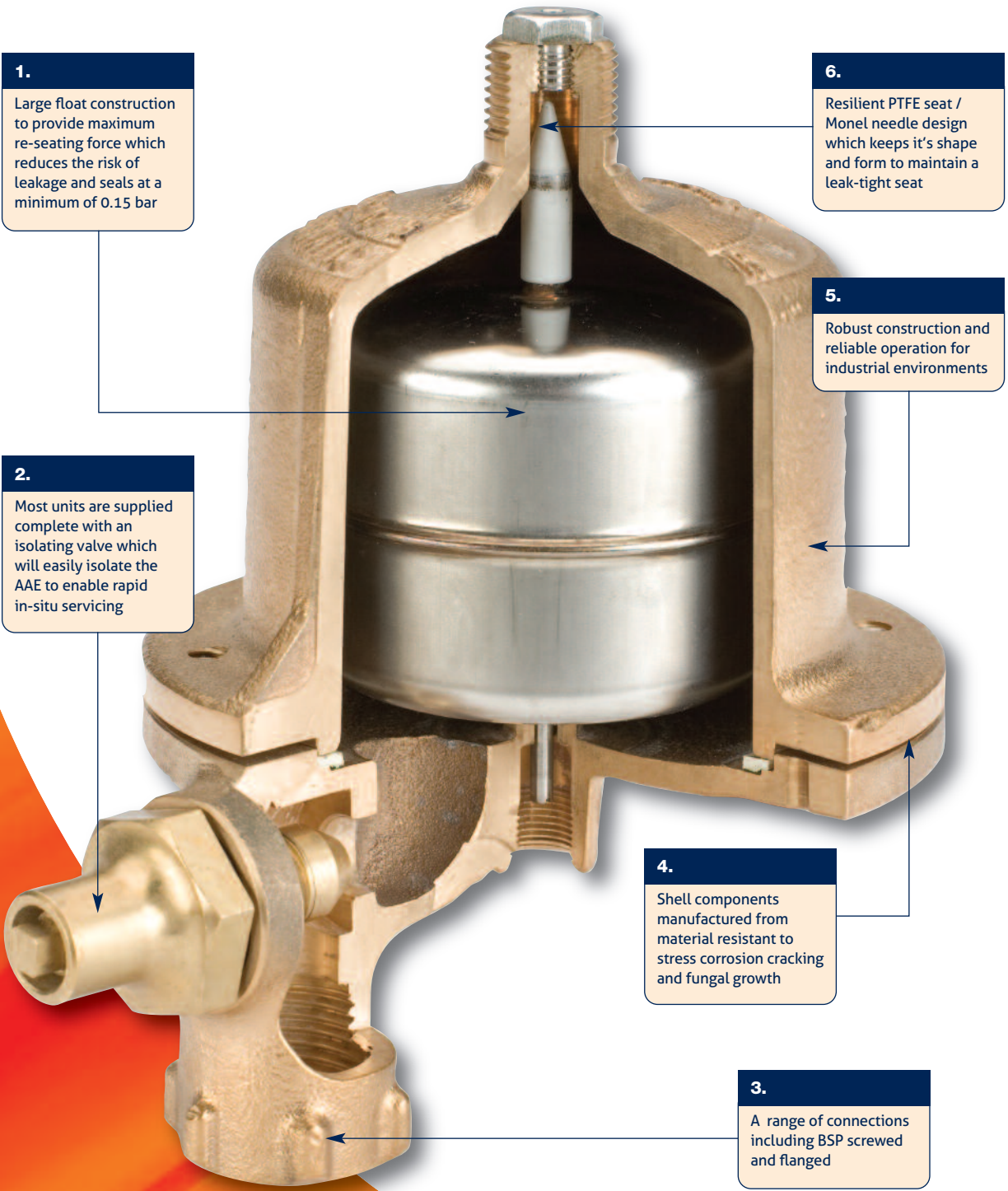

Automatic Air Eliminators

TYPE	PART NO.	DETAILS
Type A	AE-A	Vertical Inlet. Available Special Order
Type B	AE-B	Vertical Inlet with Integral Lockshield Isolating Valve
Type C	AE-C	Vertical Inlet with Integral Lockshield Isolating Valve & Check Valve
Type D	AE-D	Side Inlet Available Special Order
Type MPHW	AE-MPHW-015	Vertical Inlet with Integral Lockshield Isolating Valve
Type HPHW	AE-HPHW-F	BST'F' Vertical Inlet with Integral Lockshield Isolating Valve
Type HPHW	AE-HPHW-H	BST'H' Vertical Inlet with Integral Lockshield Isolating Valve
Type HPHW	AE-HPHW-16	PN16 Vertical Inlet with Integral Lockshield Isolating Valve
Type HPHW	AE-HPHW-150	Class 150 vertical inlet with Integral Lockshield Isolating Valve

Standard Pressure Applications - Type A, B, C and D

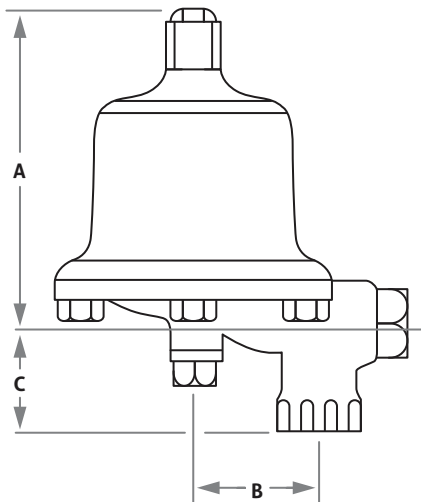

Type	A	B	C	Weight kg
A	102	43	35	1.25
B	102	43	35	1.28
C	108	43	35	1.28

Technical Data

Connections	Inlet – BS EN 10226-1:2004 – Rp ½ (Female) Outlet - BS EN ISO 228-1:2003 – G 3/8 (Male)
Pressure Rating	Up to 10 bar (150 lbf/in ²) Non-Shock
Temp Rating	Up to 93°C (200°F)
Recommended Min.Working Pressure	0.15bar (5ft effective head)

Materials of Construction

Body and Dome	Bronze (Gunmetal)
Spindle and Seating	Stainless Steel
Valve	PTFE Needle
Float	Stainless Steel



Medium Pressure Hot Water Applications - MPHW

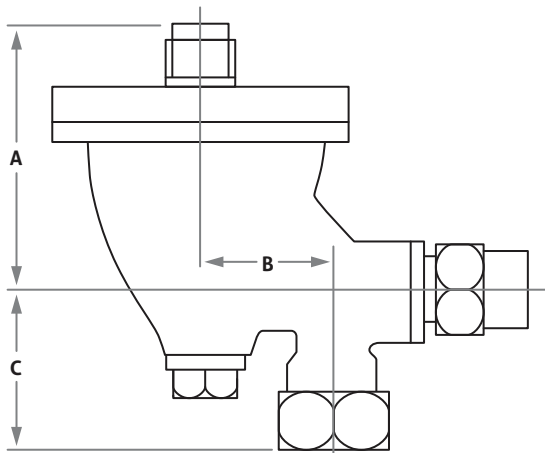

Type	A	B	C	Weight kg
MPHW	108	43	41	2.4

Technical Data

Connections	Inlet – BS EN 10226-1:2004 – Rp ½ (Female) Outlet - BS EN ISO 228-1:2003 – G 3/8 (Male)
Pressure Rating	Up to 7 bar (100 lbf/in ²)
Temp Rating	Up to 149°C (300°F)
Recommended Min. Working Pressure	0.15bar (5ft effective head)

Materials of Construction

Body and Dome	Bronze (Gunmetal)
Spindle and Seating	Stainless Steel
Valve	Monel
Float	Nickel Alloy Silver Brazed

High Pressure Hot Water Applications - HPHW

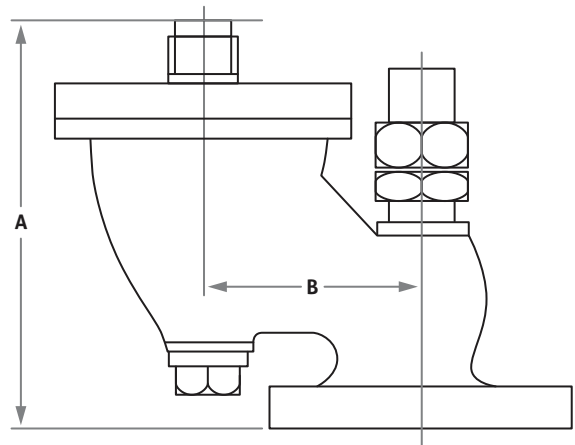

Type	A	B	Weight kg
BST 'F'	152	83	3.85
BST 'H'	152	83	3.85
PN16	152	83	3.85
Class 150	152	83	3.85

Technical Data

Connections:	Inlet – BS 10:2009 Table F or H ½" (Flanged) Can be supplied drilled to PN16 or Ansi Class 150 Outlet - BS EN ISO 228-1:2003 – G 3/8 (Male)
Pressure Rating	HPHW/F 10.5 bar (150 lbf/in ²) HPHW/H 17 bar (250 lbf/in ²)
Temp Rating	HPHW/F 182°C (360°F) HPHW/H 204°C (400°F)
Recommended Min. Working Pressure	0.15bar (5ft effective head)

Materials of Construction

Body and Dome	Bronze (Gunmetal)
Spindle and Seating	Stainless Steel
Valve	Monel
Float	Nickel Alloy Silver Brazed

Service Kits (Float Assembly) Types A, B (AE-SP-ABD) & C (AE-SP-C)

Types B and C Automatic Air Eliminators are manufactured with in-built isolating valves which, when closed, allow the dome to be removed and the float assembly replaced, allowing rapid in-situ servicing.

Type A and D require an additional isolating valve on the inlet, to isolate it from the system prior to removing the float assembly.

AE-SP-BC isolator kit available for types B & C air eliminators. AE-SP-MPHW Service kit is available for types MHPW and HPHW air eliminators.

Service kits comprise of a float assembly (inc. needle and spindle), seat, washer and retaining screws



Fig. 1688 Three-way Univent

The Figure 1688, Three-way Univent is designed for use on vented hot water systems to ensure that there is always a direct connection from the boiler/ calorifier to the atmosphere. Made from body materials resistant to stress corrosion cracking, it can be used for single or multi-boiler installations.

In-line servicing, using Univent replacement cartridges, allows valve maintenance to be carried out without disturbing the pipework.

The Univent can be opened and closed using the integral hand wheel. To close the drain port and open the vent, turn the handwheel clockwise to its full travel. Turn the handwheel anti-clockwise to open the drain and close the vent.

Technical Data

Max pressure: 7 bar

Max temperature: 93 °C

Connections: BS EN 10226-1:2004 – Rp (Female)

Materials:

Body: Bronze (Gunmetal)

Head: Bronze (Gunmetal)

Trim: Brass

Spindle: Brass bar

Renewable Seat: EPDM

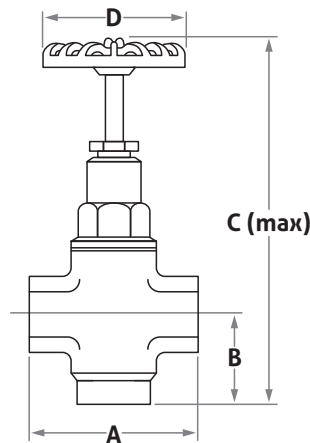

Nominal Size	Product code	A	B	C	D	Weight kg
				(max)		
25mm (1")	UV-1688-025D	96	47	200	89	1.83
32mm (1 1/4")	UV-1688-032D	118	63	237	102	2.93
40mm (1 1/2")	UV-1688-040D	144	74	269	127	4.39
50mm (2")	UV-1688-050D	160	79	283	152	6.10
65mm (2 1/2")	UV-1688-065D	190	115	395	200	14.25

Univent Replacement Cartridge (Fig.1688 only)



Replacement cartridges for the Three-way Univent valve allow rapid in-situ servicing.

Size	Product Code
25mm (1")	UV-SP-1688-025
32mm (1 1/4")	UV-SP-1688-032
40mm (1 1/2")	UV-SP-1688-040
50mm (2")	UV-SP-1688-050
65mm (2 1/2")	UV-SP-1688-065

Fig. 1988 Three-way Vent Cocks

The Figure 1988 is resistant to stress corrosion cracking and used on single, multi-boiler or calorifier installations. Fitting a Three-way Vent Cock ensures a constant connection from the boiler or calorifier to the atmosphere.

Levers are available as an optional extra.

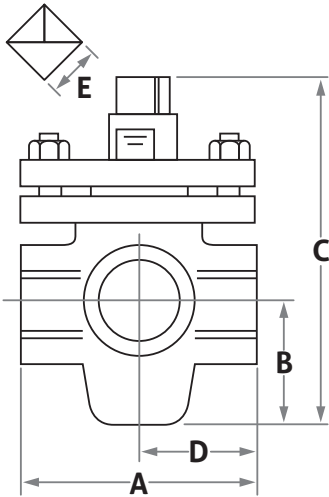

Technical Data

Max pressure: 7 bar
 Max temperature: 93 °C
 Connections: BS EN 10226-1:2004 – Rp (Female)

Materials

Body: Bronze (Gunmetal)
 Plug: Bronze (Gunmetal)
 Gland: Bronze (Gunmetal)

Normal size	Product code	A	B	C	D	E
25mm (1")	VCN-LA-025	90	43	132	45	18
32mm (1¼")	VCN-LA-032	122	48	155	56	20
40mm (1½")	VCN-LC-040	143	57	177	68	25
50mm (2")	VCN-LC-050	165	66	204	80	36

Valve Levers

Size	Product code
25mm (1")	VC-LA-025
32mm (1¼")	VC-LA-032
40mm (1½")	VC-LC-040
50mm (2")	VC-LC-050

Typical Multi-Boiler System incorporating Brownall Univents/Vent cocks Fig.1688/1988

The use of screw-down valves for multi-boiler hot water installations can allow the use of a single vent pipe to serve any number of boilers. No boiler in the system can be left in an unvented condition irrespective of the selected settings of the valves. At all times the vent valve ensures a full bore exit from the boiler to atmosphere.

In operation, clockwise turning of the handwheel closes the drain and opens the vent. Anti-clockwise rotation of the handwheel opens the drain and closes the vent.

Note: The diagram shown is schematic and is not intended as a guide to the installation of the vent valves. It is essential that vent valves are fitted in accordance with the manufacturer's recommendations and comply with Health and Safety regulations etc.

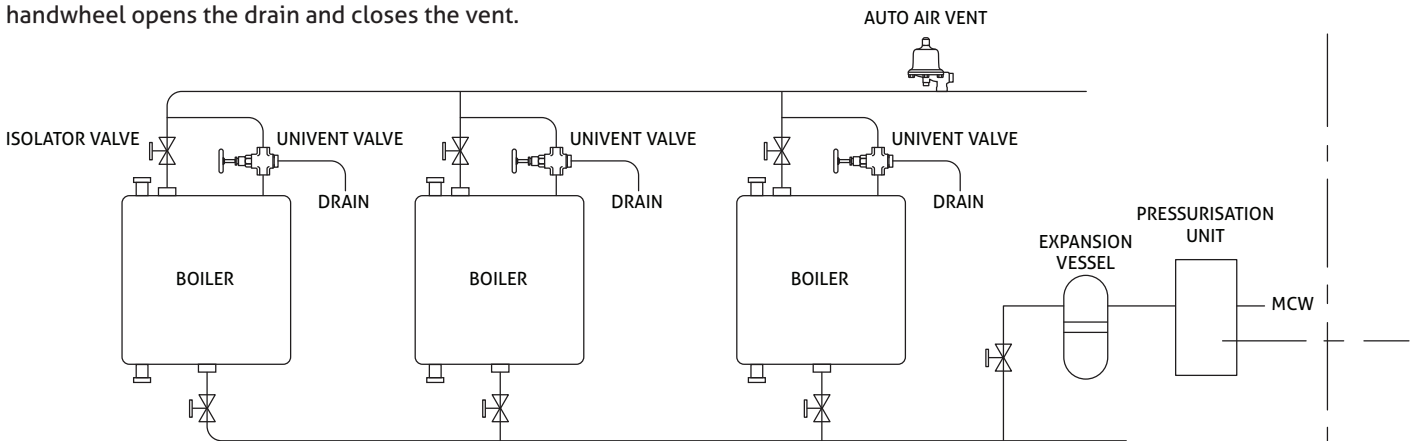

Please note Three-way Univents and Three-way Vent Cocks are interchangeable.